

REVISION HISTORY

REV	DESCRIPTION	DATE	APPROVED
	approved for production	10/1/2003	

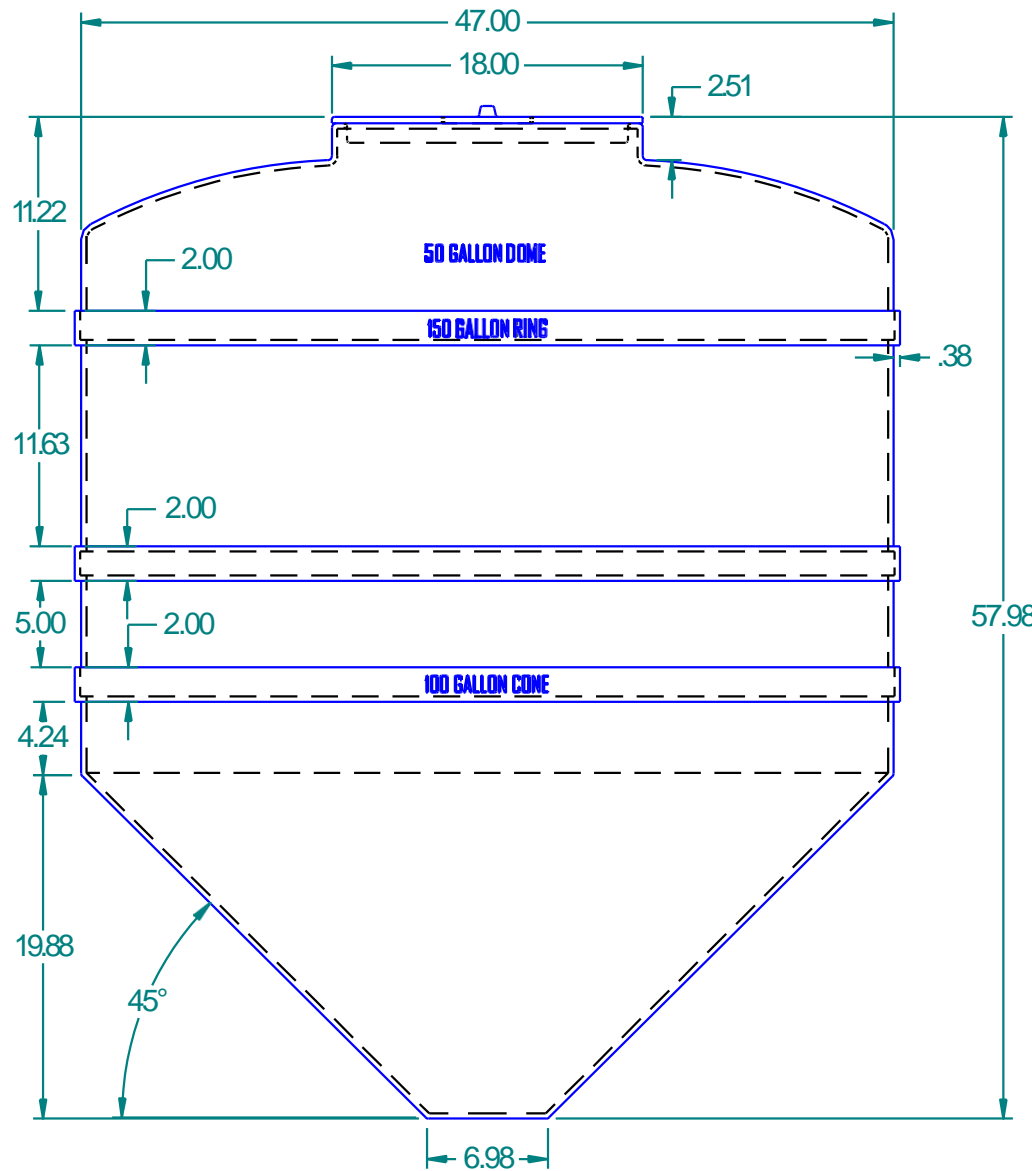

Front View

Tank Mold Assembly Requires "A" Tank Head, "C" 150 Gallon Ring, and "E" Tank Cone Sections.

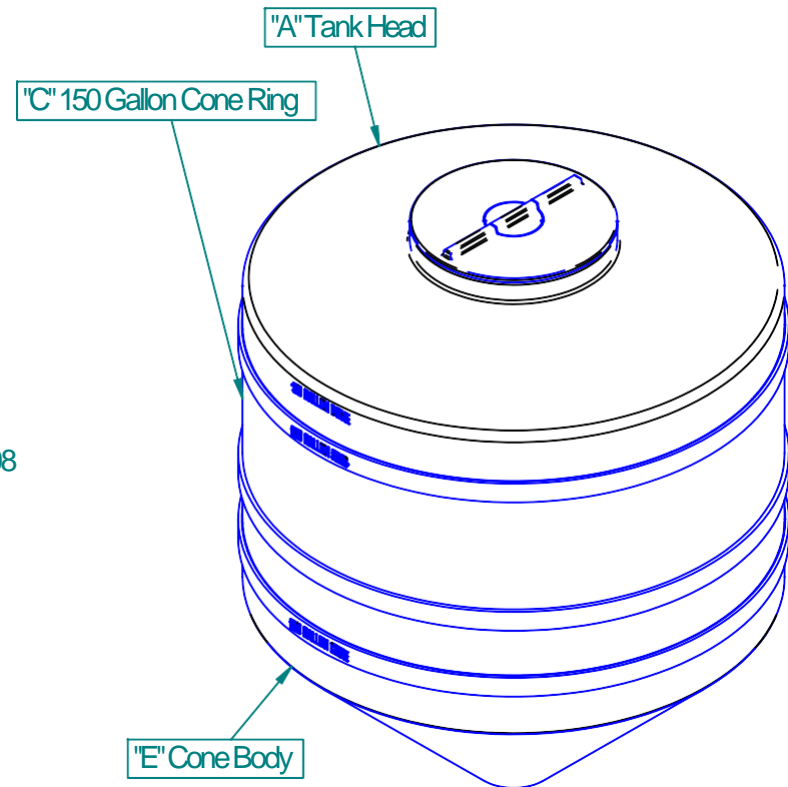

ISO View

		16160 Hwy 27 Lake Wales, FL 33859	
TITLE 300 Gallon Cone Bottom Tank			
SIZE A	MATERIAL MDPE(100)	REV	
FILE NAME 300GalConeAssy.dft			
PART# 930300HD	WEIGHT 6.691 lbm	SHEET 1 OF 1	

	NAME	DATE
DRAWN	Michael1	2/9/2004
CHECKED		
ENG APPR		
MGR APPR		

UNLESS OTHERWISE SPECIFIED
 DIMENSIONS ARE IN INCHES
 ANGLES ±0.5°
 2 PL ±0.125" 3 PL ±0.060"