

MAIN PRODUCT INFORMATION

REVISION HISTORY

REV	DESCRIPTION	DATE	APPROVED	Revised By
10	REVISED DRAWING RELEASE	8/22/2019		scloud

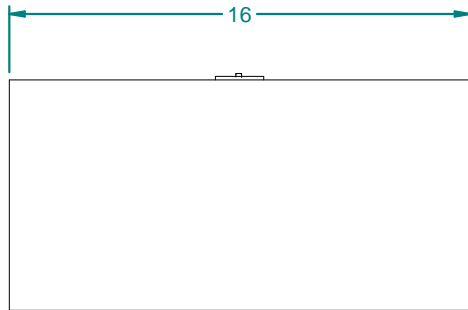
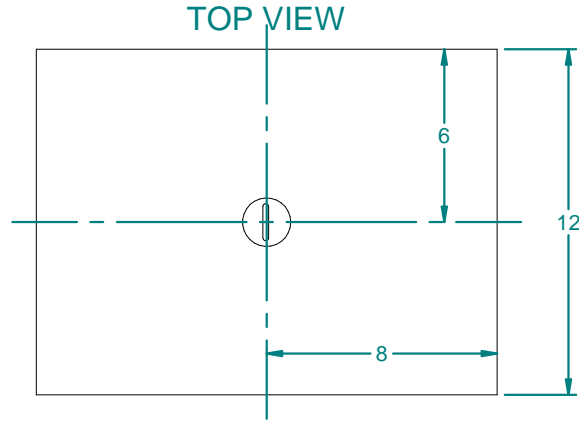

FRONT VIEW

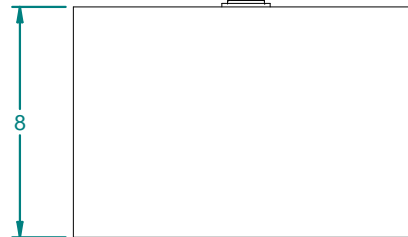

SIDE VIEW

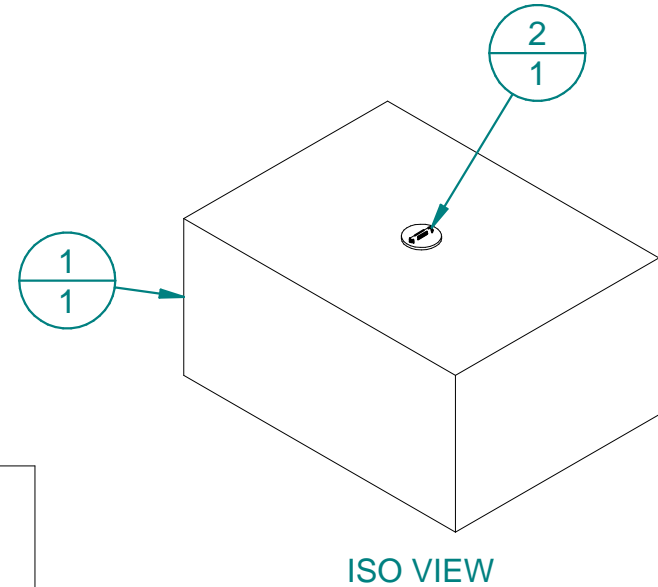

ISO VIEW

Item Number	Document Number	Title	Material	Qty
1	141006-M0100XX1	6 Gallon GP Tank	Bulk Density LLDPE (Solid)	1
2	705038	1-1/2" Patch	LDPE	1

Weight: 5.5 lbm	NAME	DATE
Wall Thickness: 0.200"	Drawn By: scloud	8/22/2019
Customer Part No: RMI 124	Customer APPR	
Print Date: 8/22/2019	Copyright©2019 Dura-Cast Products, Inc.	
UNLESS OTHERWISE SPECIFIED DIMENSIONS ARE IN INCHES AND TOLERANCES ARE: - DIMS > 10": ±1% - PARTING LINE MISMATCH: ±3/32" - DIMS < 10": ±0.100 - PARTING LINE SEAL: 2 psi - STD WELDED RADII 3/16" - WALL THICKNESS: ±20% - INSERT LOCATION: ±1% - SWF ±3/8" (FREE HAND) - FLATNESS: ±0.03 in/in - GRAPHIC LOCATION: ±1% - SWF ±1/8" + 1% (DRILL POINT)		

16160 Hwy 27 Lake Wales, FL. 33859

Customer:	Dura-Cast Products Inc.		
Part Title:	6 Gallon GP Tank		
File Name:	141006 - 6 Gallon GP tank.dft		
Size: A	Material: LLDPE 0.939	Rev: 10	
Part No: 141006-A0100XX1	Do Not Scale	Sheet: 1 OF 1	