

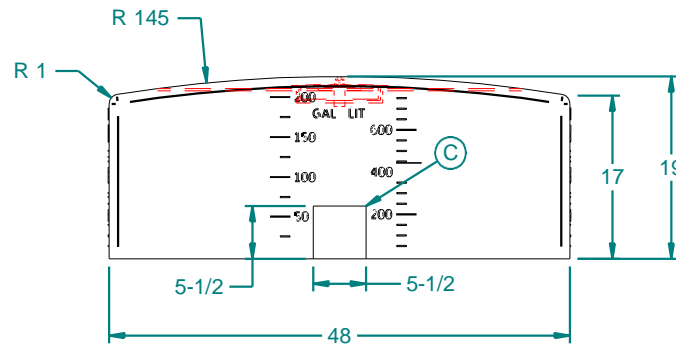

200 Gallon Low Profile Loaf Tank

REVISION HISTORY				
REV	DESCRIPTION	DATE	APPROVED	Revised By
00	Preliminary Design	6/22/2016		

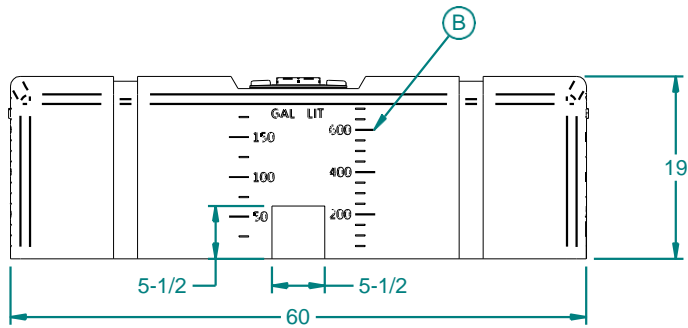
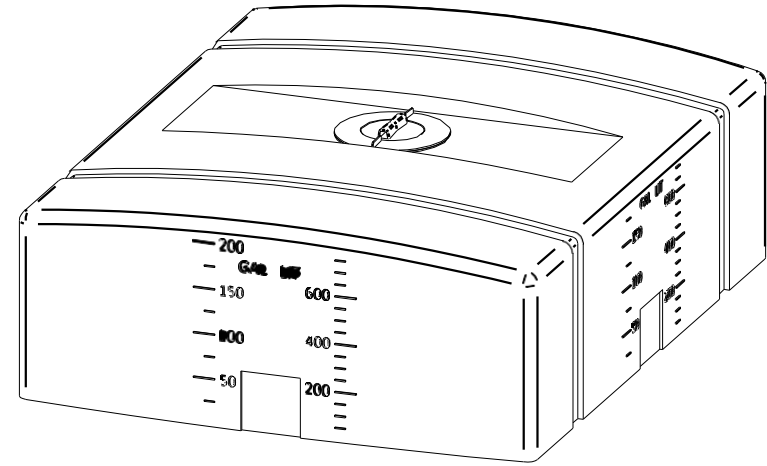
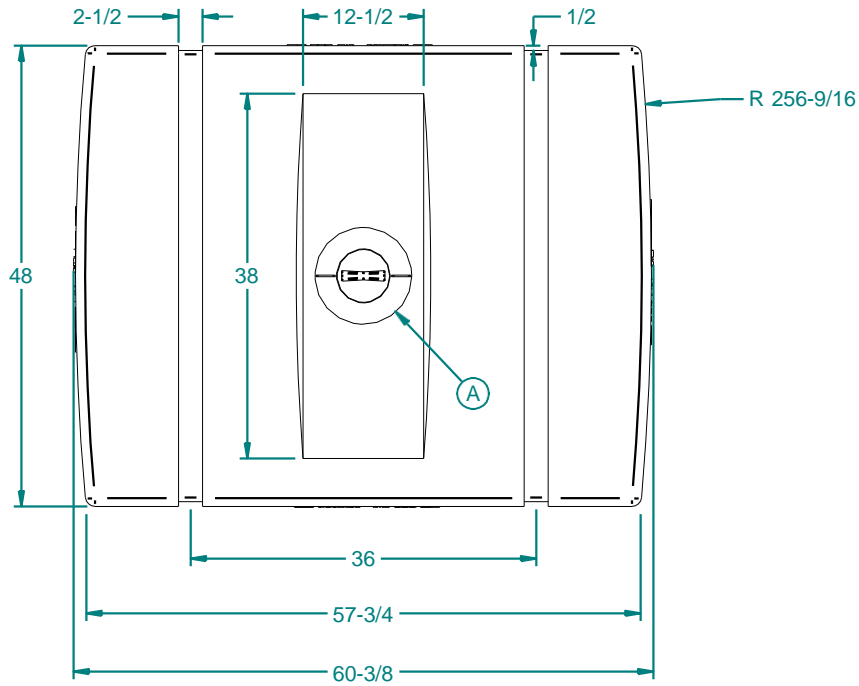

- A. 8" HDPE Threaded -Vented Manway W/ 8" Access, Black, W/ SS Screws (P/N 751008)
- B. Tank Calibration on all sides in 25 Gallon and 50 Liter Increments
- C. Tank fittings to be installed at time of shipment as per Dura-Cast procedures

Weight: 82lbm	NAME	DATE	 16160 Hwy 27 Lake Wales, FL 33859		
Wall Thickness: 0.250 in	Drawn By: S.Arant	6/22/2016			
Customer Part No: NA	Customer APPR		Customer: Dura-Cast Products, Inc.		
Print Date: 9/7/2016	Copyright © 2016 Dura-Cast Products, Inc.		Part Title: 200 Gal Low Profile Loaf Tank		
Comments: - UNLESS OTHERWISE SPECIFIED DIMENSIONS ARE IN INCHES - Std Radii 3/16"	UNLESS OTHERWISE SPECIFIED TOLERANCES ARE: DIMS > 10" ± 1% DIMS < 10" ± 0.100 WALL THICKNESS ± 20% FLATNESS ± 0.030 in/in		File Name: 200 Gal Low Profile Loaf Tank.dft		
			Size: A	Material: HDPE942	Rev: 00
			Part No: NA	Do Not Scale	Sheet: 10F1