

MAIN PRODUCT INFORMATION

REVISION HISTORY

REV	DESCRIPTION	DATE	APPROVED	Revised By
00	Prototype Release	9/11/2012		

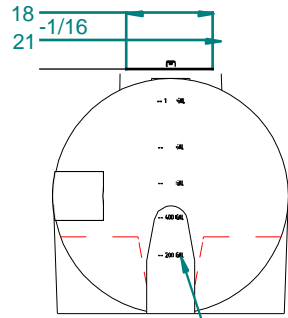
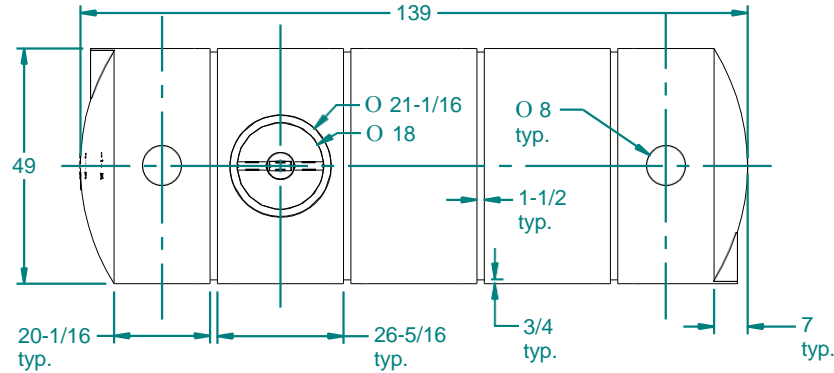

Tank calibrations in 200 Gal increments

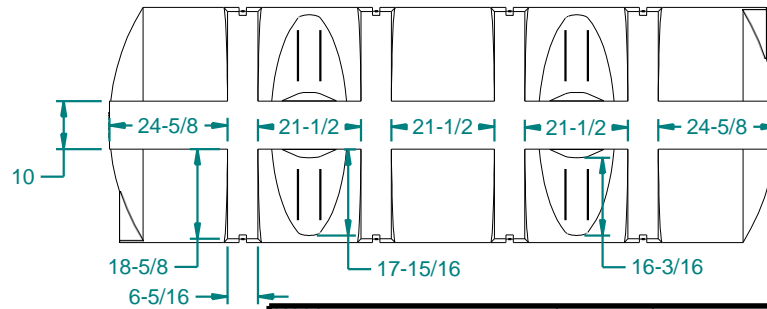
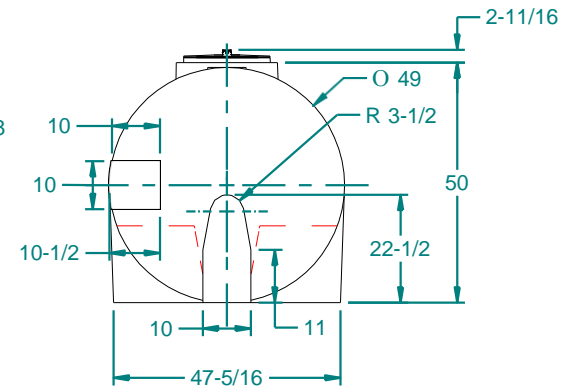
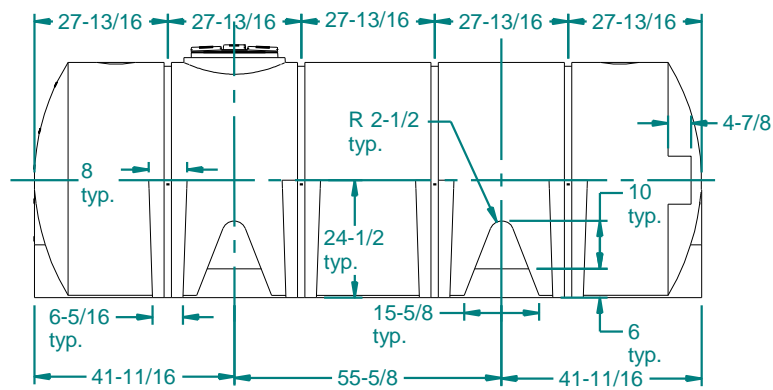

Weight: 299.679 lbm	NAME: S. Arant	DATE: 9/11/2012	 <p>16160 Hwy 27 Lake Wales, FL 33859</p>
Wall Thickness: 0.313 in	Drawn By: S. Arant	Customer APPR:	
Customer Part No: NA	Copyright © 2011 Dura-Cast Products, Inc.	Part Title: 1025 Gallon Horizontal Leg Tank	Customer: Dura-Cast Products, Inc.
Print Date: 10/13/2012	UNLESS OTHERWISE SPECIFIED TOLERANCES ARE: DIMS > 10" ± 1% DIMS < 10" ± 0.100 WALL THICKNESS ± 20% FLATNESS ± 0.030 in/in	File Name: 1025 Gallon Horizontal Leg Tank 121009.dft	Part Title: 1025 Gallon Horizontal Leg Tank
Comments: - UNLESS OTHERWISE SPECIFIED DIMENSIONS ARE IN INCHES - Std Radii 3/16"	Size: A	Material: HDPE942	Rev: 00
	Part No: 921026-A1200XX1	Do Not Scale	Sheet: 10F3

SECONDARY PRODUCT INFORMATION

REVISION HISTORY

REV	DESCRIPTION	DATE	APPROVED	Revised By
00	Prototype Release	9/11/2012		

18" HDPE Threaded - Vented Manway W/ 16" Access, Black, W/ SS Screws (P/N 751016)

Tank calibrations in 200 Gal increments

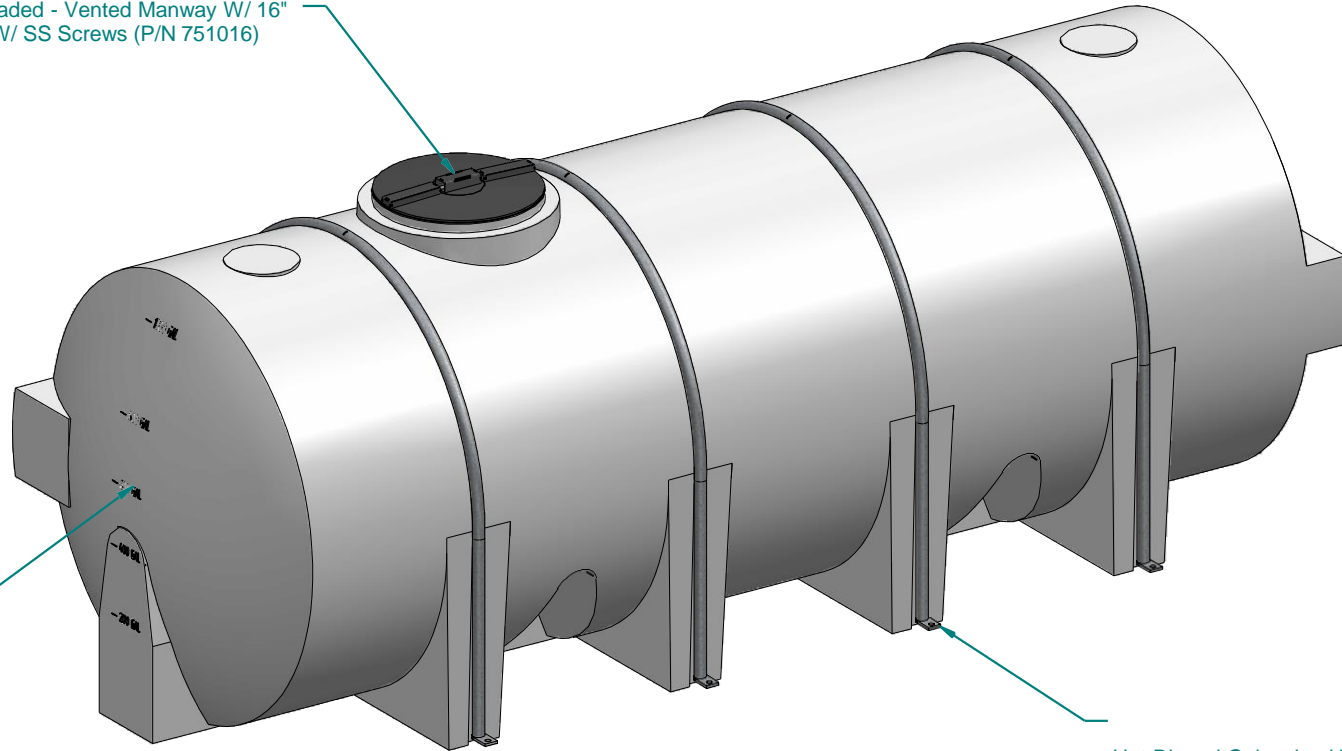

Hot-Dipped Galvanized Tank Bands,
1" Rigid Pipe (1.32" O.D., 0.13 Wall),
1.5" x 3" x 1/4" Foot w/ 5/8" Through-Hole

Weight: 369.168 lbm	NAME	DATE	 16160 Hwy 27 Lake Wales, FL 33859	
Wall Thickness: 0.313 in	Drawn By: S.Arant	9/11/2012		
Customer Part No: NA	Customer: Dura-Cast Products, Inc.	APPR	Part Title: 1025 Gallon Horizontal Leg Tank	Customer: Dura-Cast Products, Inc.
Print Date: 10/13/2012	Copyright © 2011 Dura-Cast Products, Inc.		File Name: 1025 Gallon Horizontal Leg Tank 121009.dft	
Comments: - UNLESS OTHERWISE SPECIFIED DIMENSIONS ARE IN INCHES - Std Radii 3/16"	UNLESS OTHERWISE SPECIFIED TOLERANCES ARE: DIMS > 10" ±1% DIMS < 10" ±0.100 WALL THICKNESS ±20% FLATNESS ±.030 in/in	Size: A	Material: HDPE942	Rev: 00
		Part No: 921026-A1200XX1	Do Not Scale	Sheet: 2 OF 3

Hot-Dipped Galvanized Tank Band,
 1" Rigid Pipe (1.32" O.D., 0.13 Wall),
 3" x 1-1/2" x 1/4" Foot w/ 5/8" Through-Hole

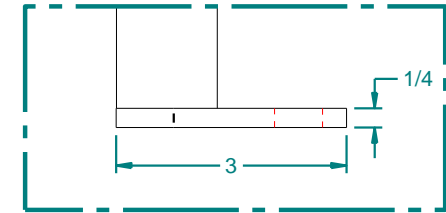
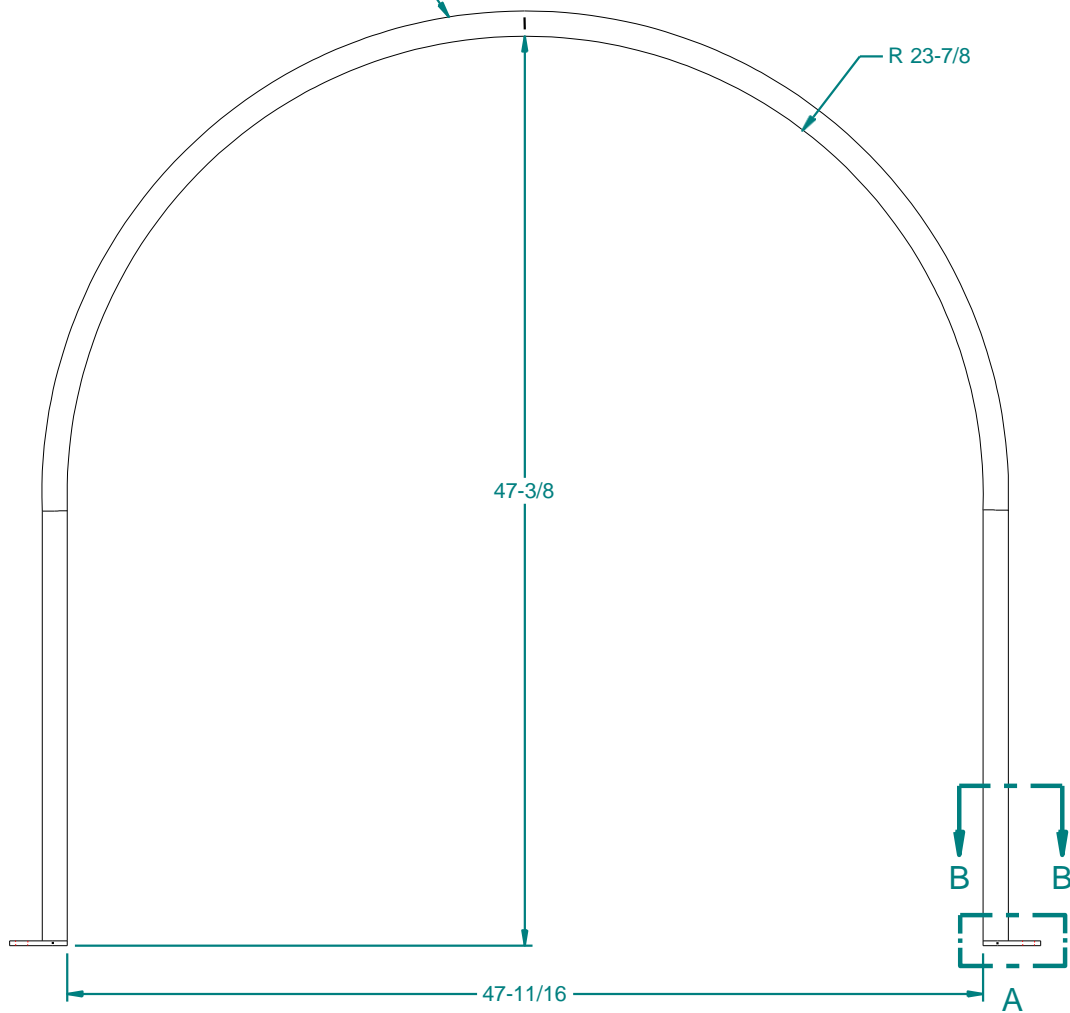

DETAIL A

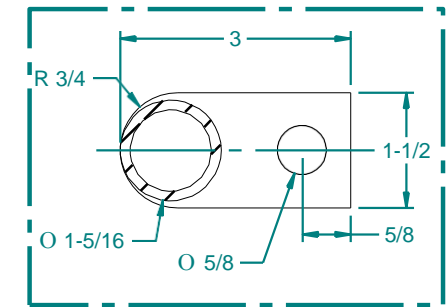

SECTION B-B

REVISION HISTORY				
REV	DESCRIPTION	DATE	APPROVED	Revised By
00	Prototype Release	9/11/2012		

Weight: 17011 lbm	NAME: S. Arant	DATE: 9/11/2012	 16160 Hwy 27 Lake Wales, FL 33859
Wall Thickness: NA	Drawn By: S. Arant	9/11/2012	
Customer Part No: NA	Customer APPR:		Customer: Dura-Cast Products, Inc.
Print Date: 10/13/2012	Copyright © 2011 Dura-Cast Products, Inc.		Part Title: 1025 Gallon Horizontal Leg Tank
Comments: - UNLESS OTHERWISE SPECIFIED DIMENSIONS ARE IN INCHES - Std Radii 3/16"	UNLESS OTHERWISE SPECIFIED TOLERANCES ARE: DIMS > 10" ± 1% DIMS < 10" ± 0.100 WALL THICKNESS ± 20% FLATNESS ± .030 in/in		File Name: 1025 Gallon Horizontal Leg Tank 121009.dft
			Size: A
Part No: 921026F0XXXXX1		Do Not Scale	Sheet: 3 OF 3