

920202 200 Gallon Low Profile Loaf Tank

REVISION HISTORY

REV	DESCRIPTION	DATE	APPROVED	Revised By
10	Production Release	1/3/2017		

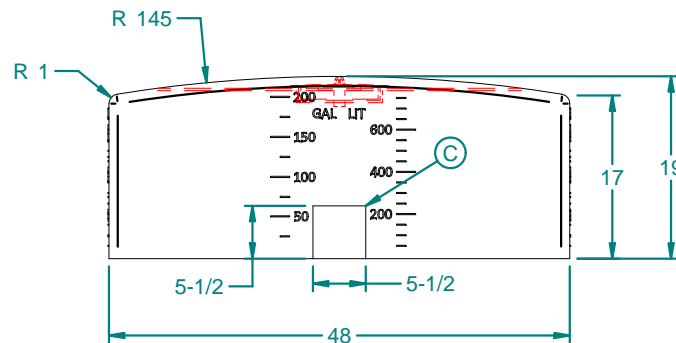
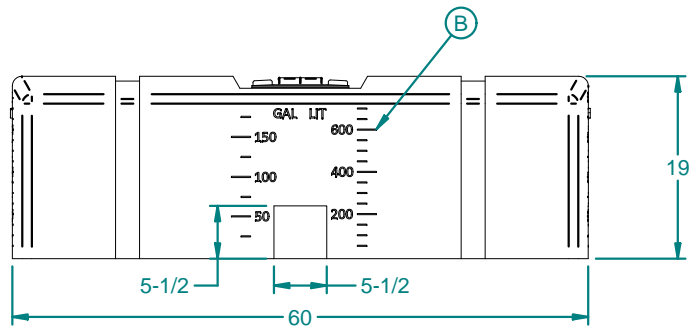
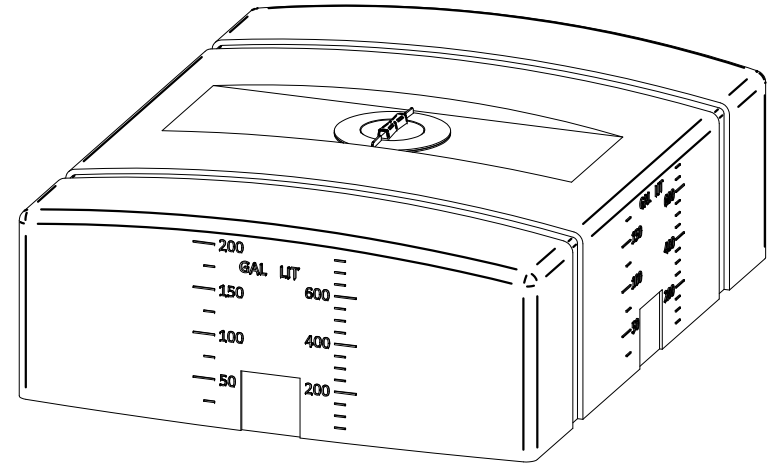
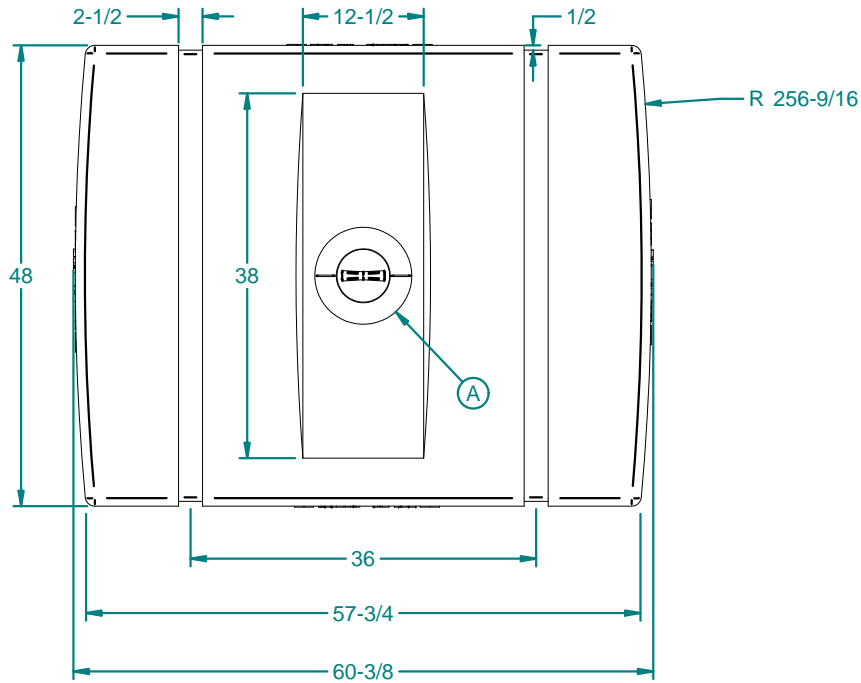

A. 8" HDPE THREADED - VENTED MANWAY W/ 8" ACCESS, BLACK, W/ SS SCREWS (P/N 751008)

B. TANK CALIBRATION ON ALL SIDES IN 25 GALLON AND 50 LITER INCREMENTS

C. TANK FITTINGS TO BE INSTALLED AT TIME OF SHIPMENT AS PER DURA-CAST PROCEDURES

Weight: 81 lbm	NAME	DATE	 16160 Hwy 27 Lake Wales, FL. 33859		
Wall Thickness: 0.250 in	Drawn By: P. Villa	6/22/2016			
Customer Part No: N/A	Customer APPR		Customer: Dura-Cast Products, Inc.		
Print Date: 11/2/2017	COPYRIGHT©2016 DURA-CAST PRODUCTS, INC.		Part Title: 200 Gal Low Profile Loaf Tank		
Comments: - UNLESS OTHERWISE SPECIFIED DIMENSIONS ARE IN INCHES - Std Radii 3/16"	UNLESS OTHERWISE SPECIFIED TOLERANCES ARE DIMS > 10" ±1% DIMS < 10" ±0.100 WALL THICKNESS ± 20% FLATNESS ± .030 in/in		File Name: 200 Gal Low Profile Loaf Tank.dft		
			Size: A	Material: HDPE 942	Rev: 10
			Part No: 920202-A0100XXI	Do Not Scale	Sheet: 1 OF 1