

REVISION HISTORY

REV	DESCRIPTION	DATE	APPROVED	Revised By
00	PROTOT RELEASE YPE	03/14/16		

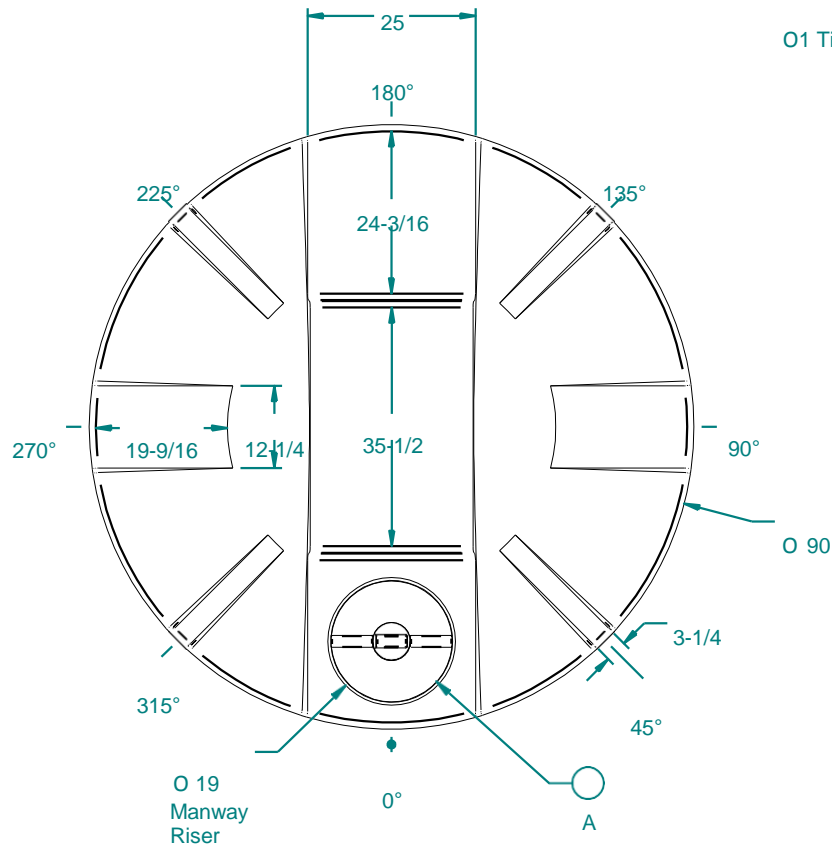

O1 Tiedown Lugs

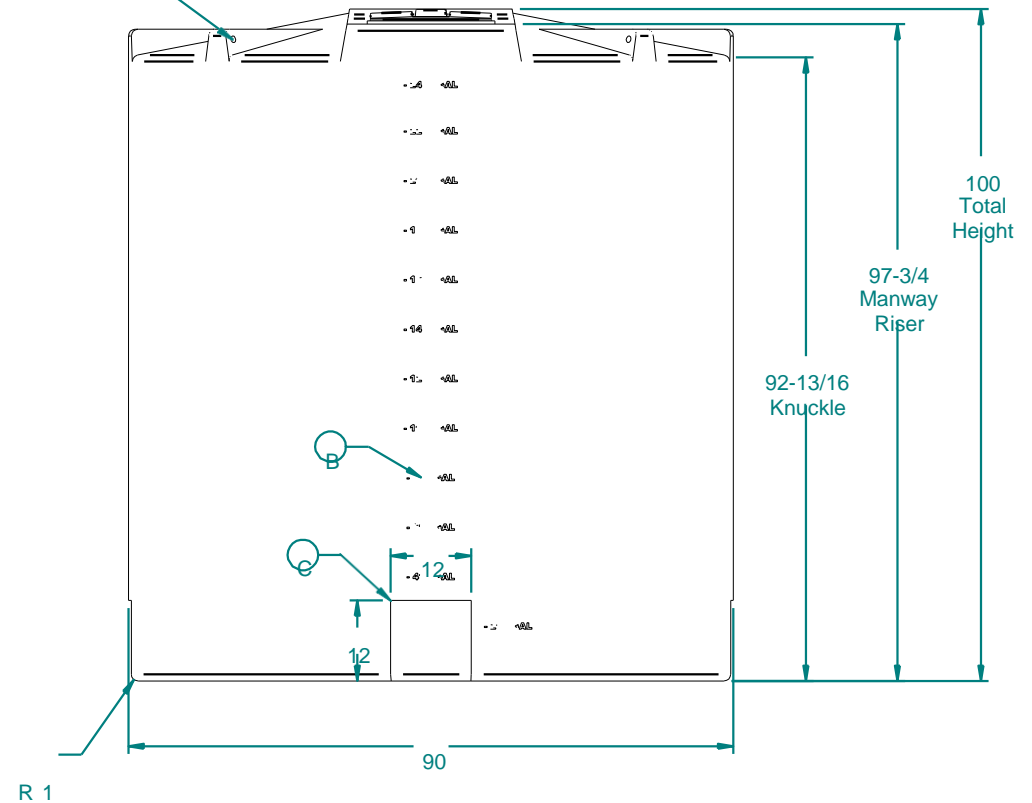

A. 16" HDPE Threaded - Vented Manway W/ 16" Access, Black, W/ SS Screws (P/N 751008)

B. Tank Calibration At 0 in 200 Gal Increments

C. Tank fittings to be installed at time of shipment as per Dura-Cast procedures

Weight 350 lbm	NAME S. Arant	DATE 6/3/2015	 <p>16160 Hwy 27 Lake Wales, FL 33859</p>
Wall Thickness: 0.250 in	Drawn By: Customer APPR		
Customer Part No: NA	Print Date: 3/14/2016	Copyright © 2016 Dura-Cast Products, Inc.	Part Title: 2500 Gal 90x100 Vertical Tank
Comments: - UNLESS OTHERWISE SPECIFIED DIMENSIONS ARE IN INCHES - Std Radii 3/16"	UNLESS OTHERWISE SPECIFIED TOLERANCES ARE DIMS > 10" ± 1% DIMS < 10" ± 0.100 WALL THICKNESS ± 20% FLATNESS ± 0.030 in/in		File Name: 2500 Gal 90x100 Vertical Tank.dft
	Size A	Material: HDPE 942	Rev.
Part No: 902501-A0200XX1	Do Not Scale	Sheet: 10F3	

2500 Gal 90x100 Vertical Tank Fitment  
Standard Dry Van Trailer Dimensions

REVISION HISTORY				
REV	DESCRIPTION	DATE	APPROVED	Revised By
00	PROTOTYPE RELEASE	03/14/16 93		

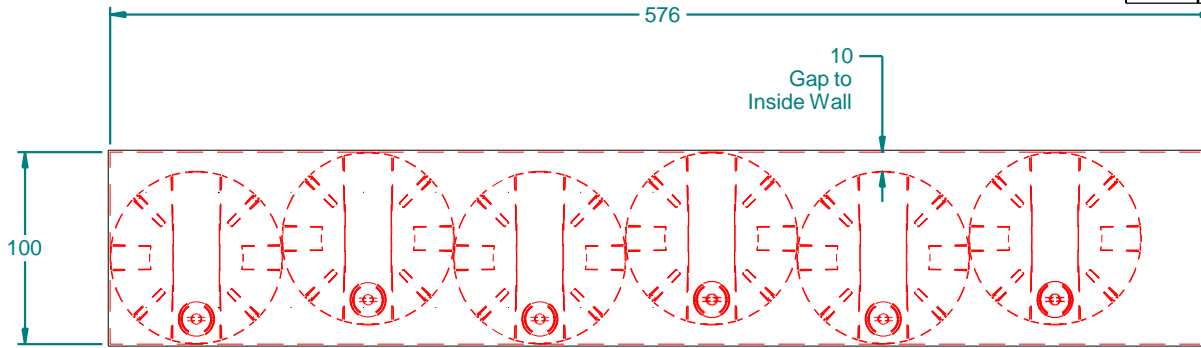

6 Tanks in 48' Dry Van

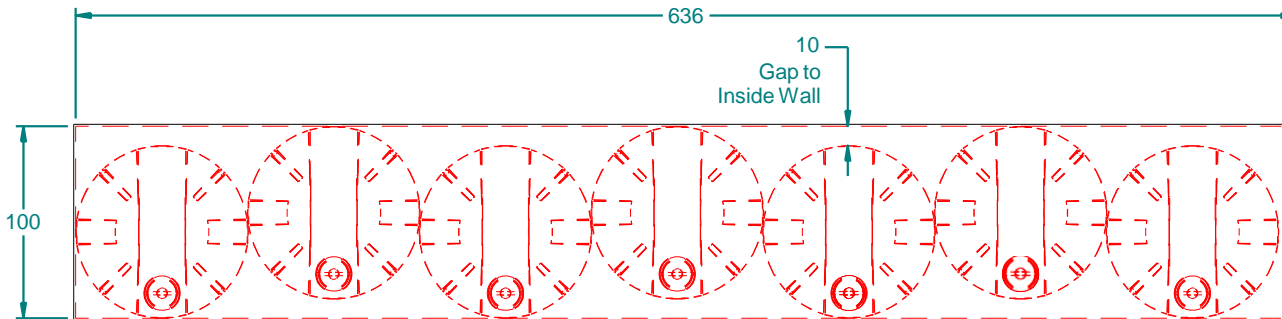

7 Tanks in 53' Dry Van

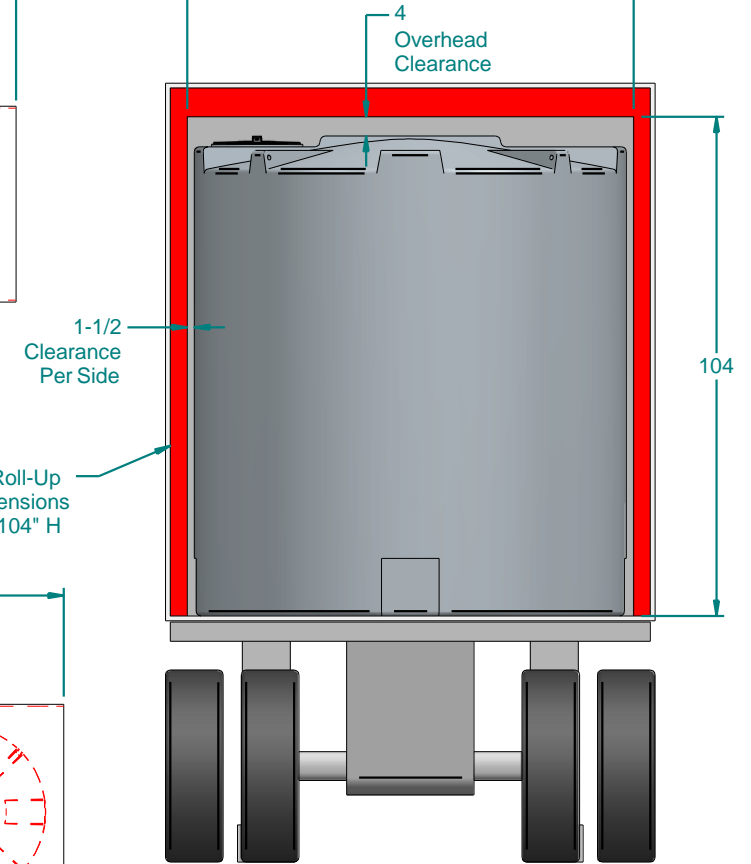

Weight: 350 lbm	NAME S. Arant	DATE 6/3/2015	 <p>16160 Hwy 27 Lake Wales, FL 33859</p>
Wall Thickness: 0.250 in	Drawn By:	Customer APPR:	
Customer Part No: NA	Copyright © 2016 Dura-Cast Products, Inc.		Customer: Dura-Cast Products, Inc.
Print Date: 3/14/2016	UNLESS OTHERWISE SPECIFIED TOLERANCES ARE: DIMS > 10" ±1% DIMS < 10" ±0.100 WALL THICKNESS ±20% FLATNESS ± .030 in/in		Part Title: 2500 Gal 90x100 Vertical Tank
Comments: - UNLESS OTHERWISE SPECIFIED DIMENSIONS ARE IN INCHES - Std Radii 3/16"	File Name: 2500 Gal 90x100 Vertical Tank.dft		Size: A
	Material: HDPE 942		Rev:
Part No: 902501-A0200XX1	Do Not Scale	Sheet: 2 OF 3	

90x100 2500 Gal Vertical Tank  
Standard 53-ft High Cube Container Dimensions

REVISION HISTORY

REV	DESCRIPTION	DATE	APPROVED	Revised By
00	PROTOTYPE RELEASE	03/14/16		

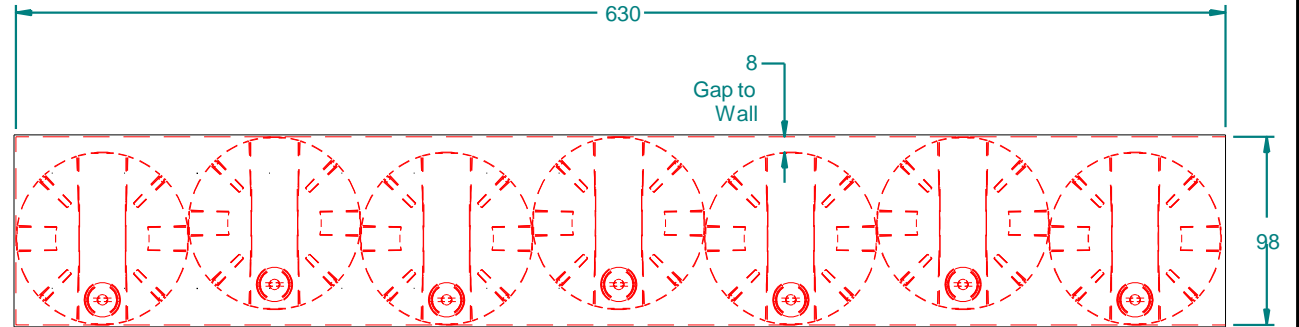
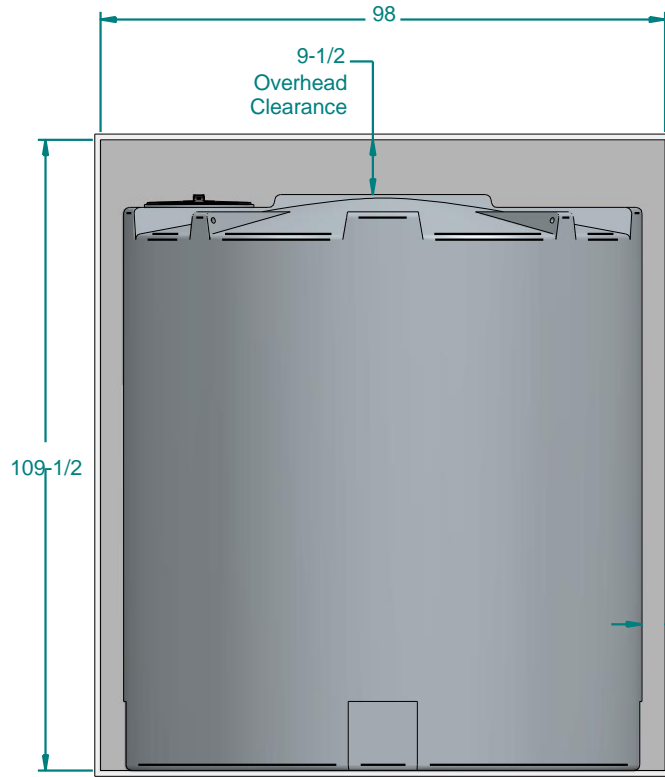

7 Tanks in 53' High Cube Container

Weight: 350 lbm	NAME	DATE	 16160 Hwy 27 Lake Wales, FL 33859 Customer: Dura-Cast Products, Inc.
Wall Thickness: 0.250 in	Drawn By: S.Arant	6/3/2015	
Customer Part No: NA	Customer APPR		Part Title: 2500 Gal 90x100 Vertical Tank
Print Date: 3/14/2016	Copyright © 2016 Dura-Cast Products, Inc.		File Name: 2500 Gal 90x100 Vertical Tank.dft
Comments: - UNLESS OTHERWISE SPECIFIED DIMENSIONS ARE IN INCHES - Std Radii 3/16"	UNLESS OTHERWISE SPECIFIED TOLERANCES ARE DIMS > 10" ±1% DIMS < 10" ±0.100 WALL THICKNESS ±20% FLATNESS ±.030 in/in		Size: A Material: HDPE 942 Rev.
	Part No: 902501-A0200XX1	Do Not Scale	Sheet: 3 OF 3