

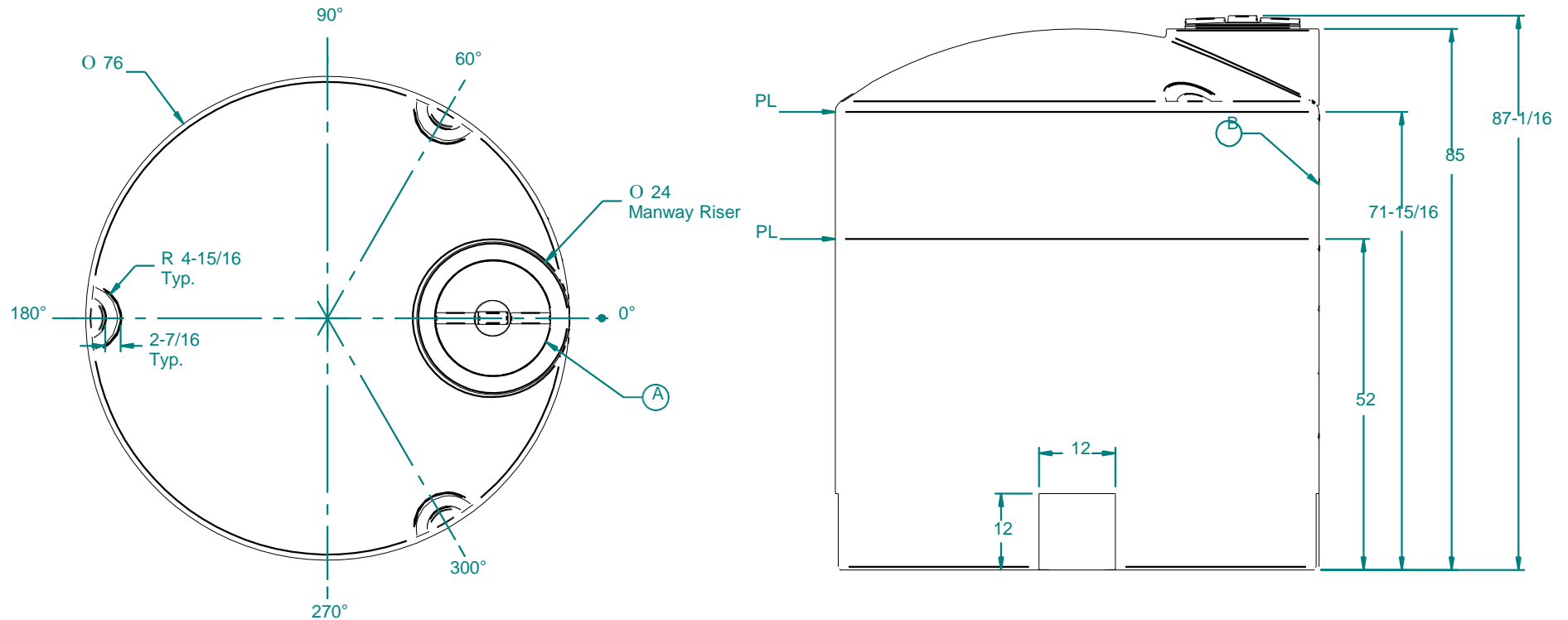

1550 Gallon Vertical Tank



- A. 16" HDPE Threaded, Vented Manway, W/ 16" Access, Black, W/ SS Screws (P/N 751016)
- B. Tank Calibration At 0 in 200 Gallon Increments
- C. Tank fittings to be installed at time of shipment as per Dura-Cast procedures

Weight: Dependent on specific gravity rating	NAME	DATE	
Wall Thickness: Dependent on specific gravity rating	Drawn By: S.Arant	7/25/2014	
Customer Part No: NA	Customer: Dura-Cast Products, Inc.	Part Title: 1550 Gallon Vertical Tank	16160 Hwy 27 Lake Wales, FL 33859
Print Date: 7/25/2014	Copyright © 2014 Dura-Cast Products, Inc.	File Name: 1550 Gal Vertical Tank.dft	Customer: Dura-Cast Products, Inc.
Comments: - UNLESS OTHERWISE SPECIFIED DIMENSIONS ARE IN INCHES - Std Radii 3/16"	UNLESS OTHERWISE SPECIFIED TOLERANCES ARE DIMS > 10" ± 1% DIMS < 10" ± 0.100 WALL THICKNESS ± 20% FLATNESS ± .030 in/in	Size: A	Material: HDPE 942
		Part No: 901600	Rev.
		Do Not Scale	Sheet: 10F1