

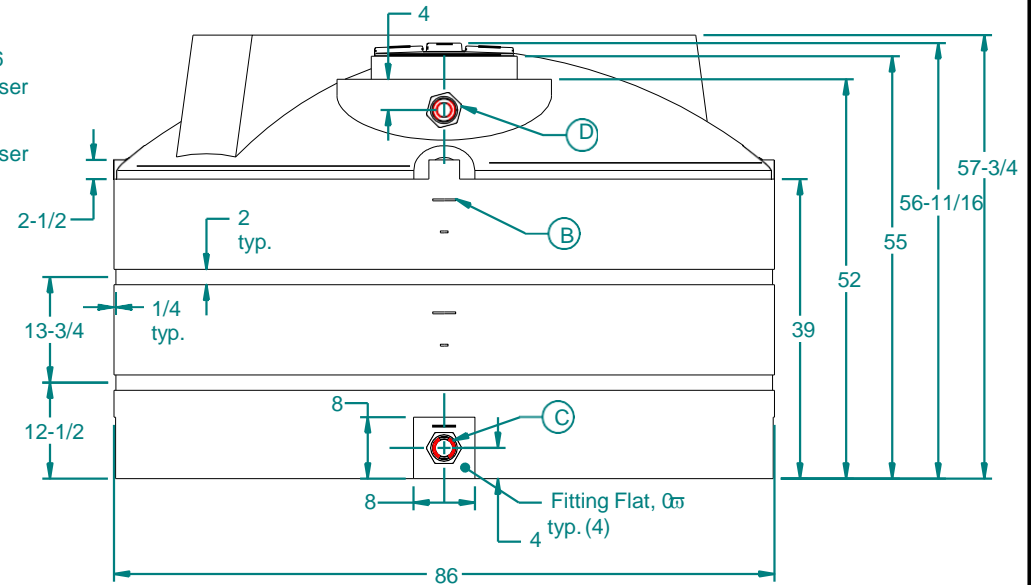

1100 Gallon Vertical Water Tank

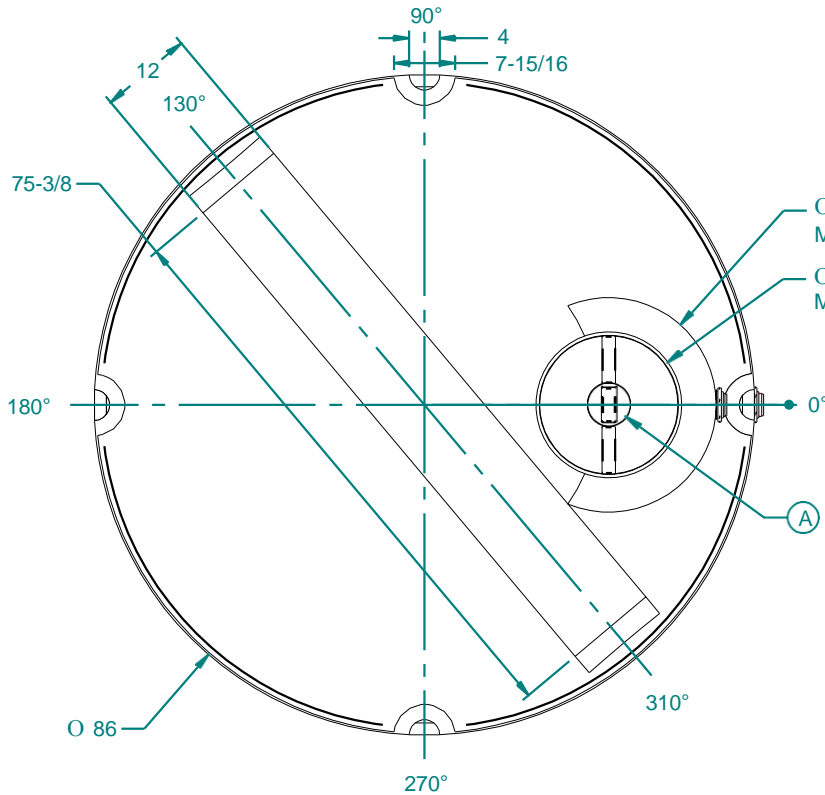

- A. 18" HDPE Threaded -Vented Manway W/ 16" Access, Black, W/ SS Screws (P/N 751016)
- B. Tank Calibration At ϕ in 250 Gallon Increments
- C. 2" polypro tank fitting to be installed at time of shipment as per Dura-Cast procedures
- D. 1-1/2" polypro tank fitting to be installed at time of shipment as per Dura-Cast procedures

Weight: Dependent on specific gravity rating		NAME	DATE	 16160 Hwy 27 Lake Wales, FL 33859
Wall Thickness: Dependent on specific gravity rating	Drawn By:	S.Arant	10/1/2012	
Customer Part No: NA	Customer APFR			Customer: Dura-Cast Products, Inc.
Print Date: 10/1/2012	Copyright © 2012 Dura-Cast Products, Inc.			Part Title: 1100 Gallon Vertical Water Tank
Comments: - UNLESS OTHERWISE SPECIFIED DIMENSIONS ARE IN INCHES - Std Radii 3/16"	UNLESS OTHERWISE SPECIFIED TOLERANCES ARE: DIMS > 10" ± 1% DIMS < 10" ± 0.100 WALL THICKNESS ± 20% FLATNESS ± 0.030 in/in			File Name: 901100 1100 Gallon Vertical Water Tank.dft
	Size: A	Material: HDPE 942		Rev.
	Part No: 901100	Do Not Scale	Sheet: 10F1	