

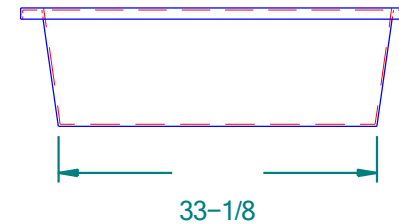

MAIN PRODUCT INFORMATION

REVISION HISTORY

REV	DESCRIPTION	DATE	APPROVED	Revised By
A	Initial Design Release	6/22/2016		

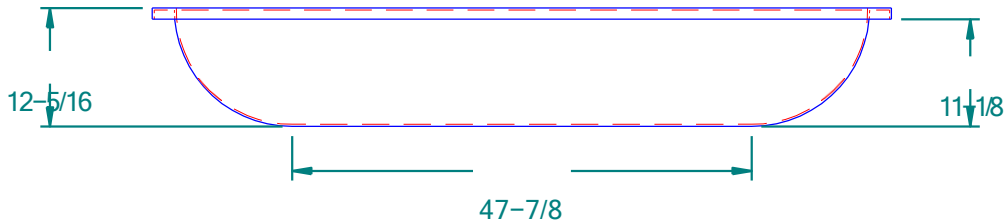
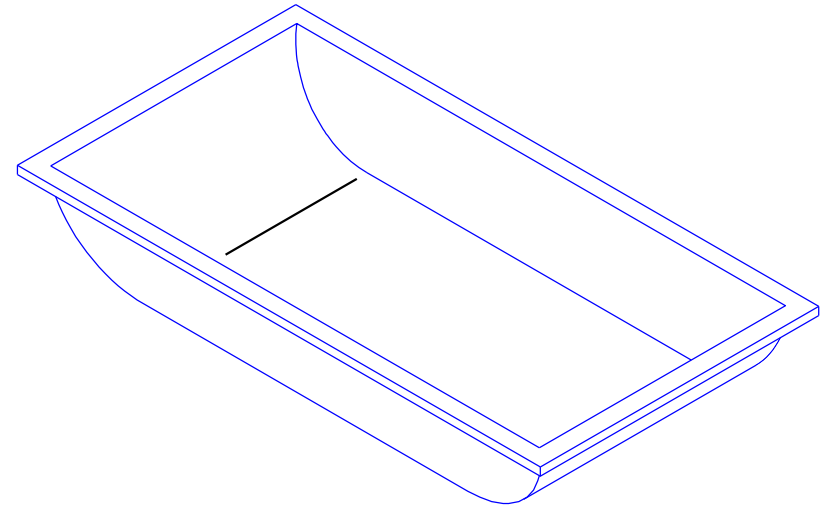
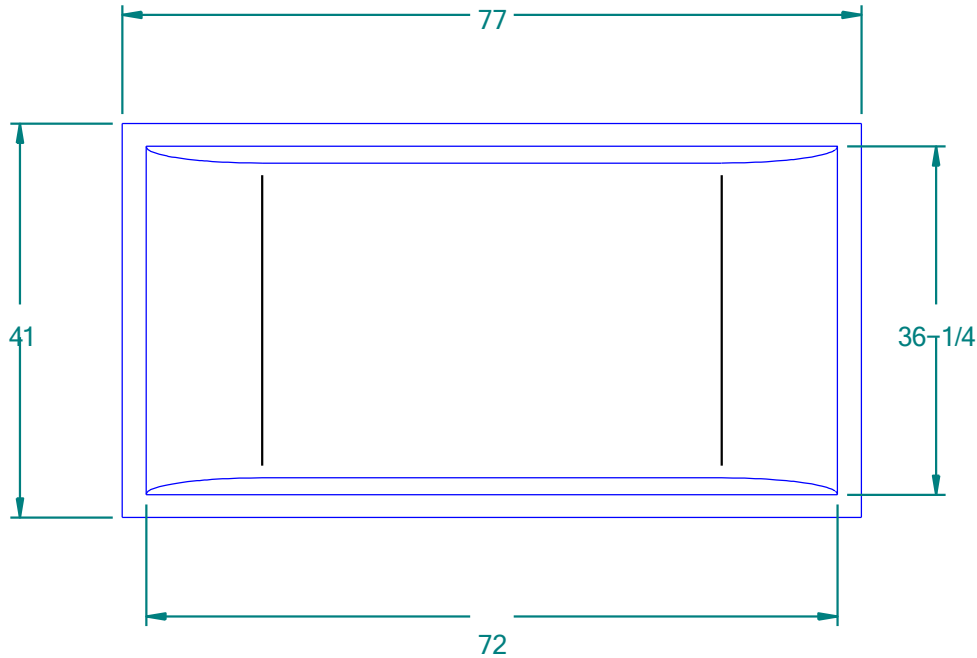

NOTE: OPEN TANK WILL NEED SUPPORT IF FILLING UP BEYOND HALF WAY

Weight: 35.170 lbm	NAME	DATE	 <p>16160 Hwy 27 Lake Wales, FL 33859</p>
Wall Thickness: 0.208 in	Drawn By: mnegron	6/22/2016	
Customer Part No: n/a	Customer: APPR		Customer: Dura-Cast Products, Inc.
Print Date: 6/7/2018	Copyright © 2007 Dura-Cast Products, Inc.		Part Title: 6' Mortar Box - Open Top Tank
Comments: - UNLESS OTHERWISE SPECIFIED DIMENSIONS ARE IN INCHES - Std Radii 3/16"	Tolerance: UNLESS OTHERWISE SPECIFIED TOLERANCES ARE ±1%		File Name: 501230 Open Top.dft
	Size: A	Material: Polyethylene, low density	Rev: A
	Part No: 501230	Do Not Scale	Sheet: 1 OF 1