

REVISION HISTORY

REV	DESCRIPTION	DATE	APPROVED	Revised By
01	Existing Part Dimensional Drawing	6/22/2016		

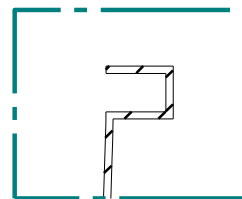

Typical Tank Lip Treatment SECTION A-A

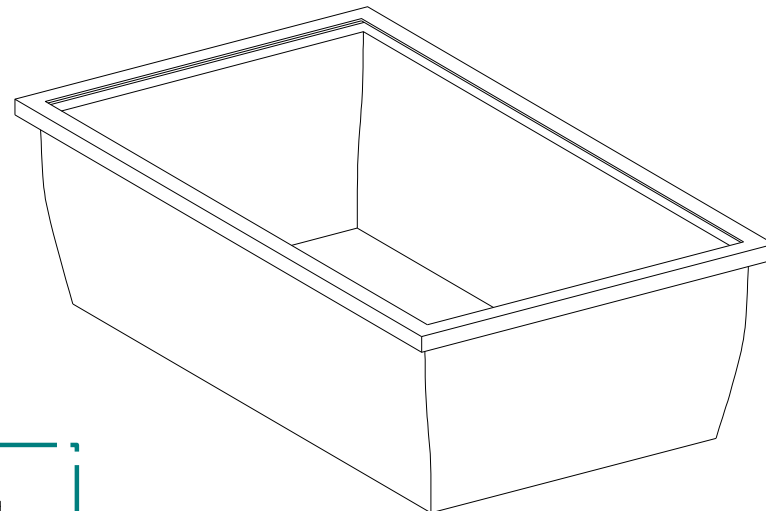
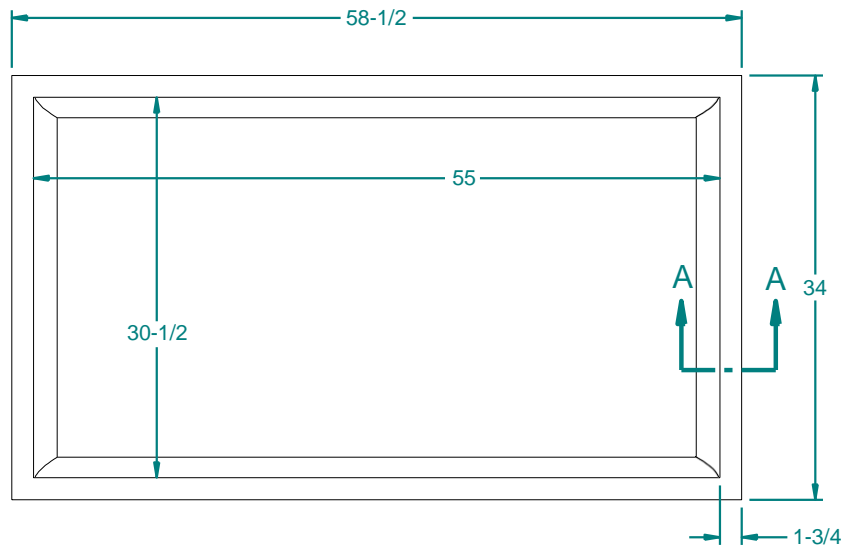
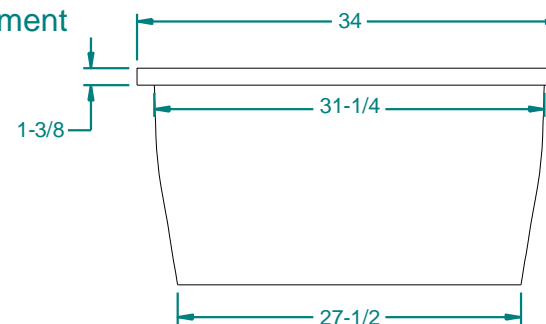
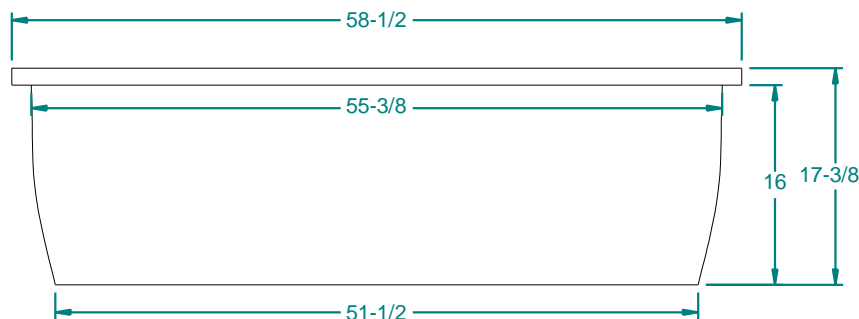

NOTE: Not For Use As A Shop Floor Drawing

NOTE: OPENTANK WILL NEED SUPPORT IF FILLING UP BEYOND HALF WAY

Weight: 44 lbm	Drawn By: S.Arant	NAME: S.Arant	DATE: 6/22/2016	 16160 Hwy 27 Lake Wales, FL 33859
Wall Thickness: 0.187 in	Customer APPR:	Customer:	Customer: Dura-Cast Products, Inc.	
Customer Part No: NA	Print Date: 6/7/2018	Copyright © 2012 Dura-Cast Products, Inc.		Part Title: Rectangular Breeder Bin
Comments: - UNLESS OTHERWISE SPECIFIED DIMENSIONS ARE IN INCHES - Std Radii 3/16"	UNLESS OTHERWISE SPECIFIED TOLERANCES ARE: DIMS > 10" ±1% DIMS < 10" ±0.100 WALL THICKNESS ±20% FLATNESS ±.030 in/in		File Name: 501170AQ Rectangular Breeder Bin.dft	Rev: 01
	Size: A	Material: LLDPE 939	Part No: 501170AQ	Do Not Scale Sheet 10F1