

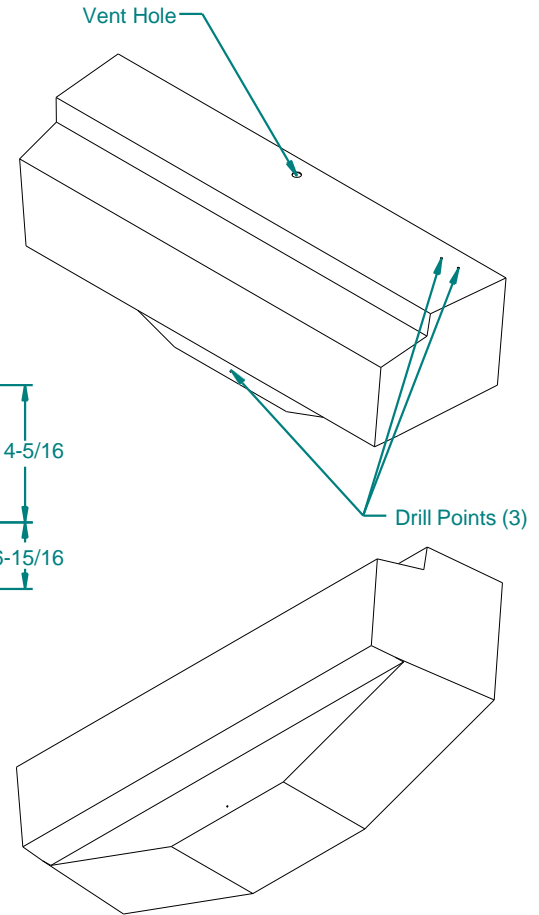

MAIN PRODUCT INFORMATION

REVISION HISTORY

REV	DESCRIPTION	DATE	APPROVED	Revise By d
01	Existing Part Dimensional Drawing	11/2/2012		

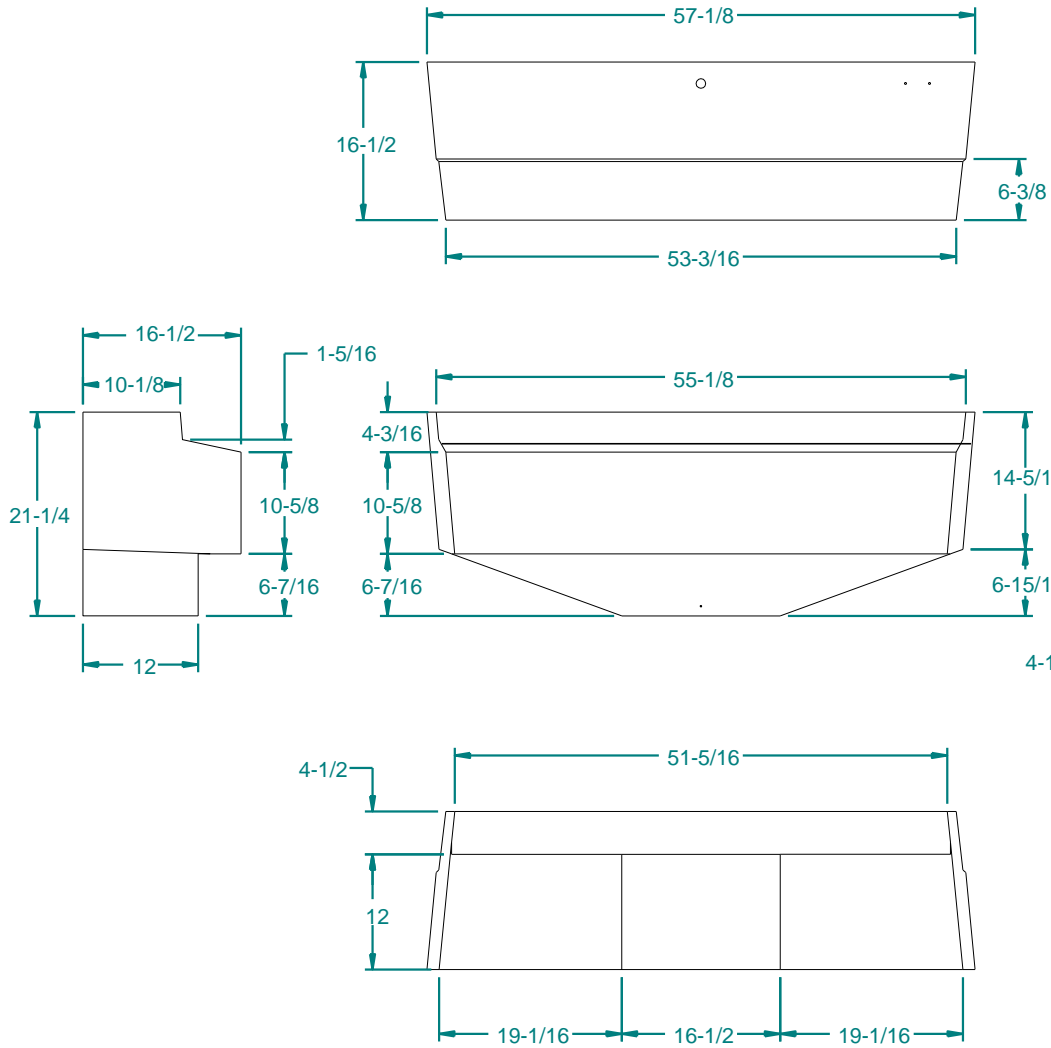

Weight: NA	NAME	DATE	 16160 Hwy 27 Lake Wales, FL 33859	
Wall Thickness: 0.250 in	Drawn By: S.Arant	11/2/2012		
Customer Part No: NA	Customer APPR		Customer: Dura-Cast Products, Inc.	
Print Date: 11/2/2012	Copyright © 2012 Dura-Cast Products, Inc.		Part Title: 60 Gallon Holding Tank	
Comments: - UNLESS OTHERWISE SPECIFIED DIMENSIONS ARE IN INCHES - Std Radii 3/16"	UNLESS OTHERWISE SPECIFIED TOLERANCES ARE DIMS > 10" ±1% DIMS < 10" ±0.100 WALL THICKNESS ±20% FLATNESS ±.030 in/in		File Name: 208060 60 Gallon Holding Tank.dft	
			Size: A	Material: LLDPE 939
			Part No: 208060	Do Not Scale Sheet: 10F1