

REVISION HISTORY

REV	DESCRIPTION	DATE	APPROVED	Revised By
00	DRAWN IN CAD	12/05/19		mnegron

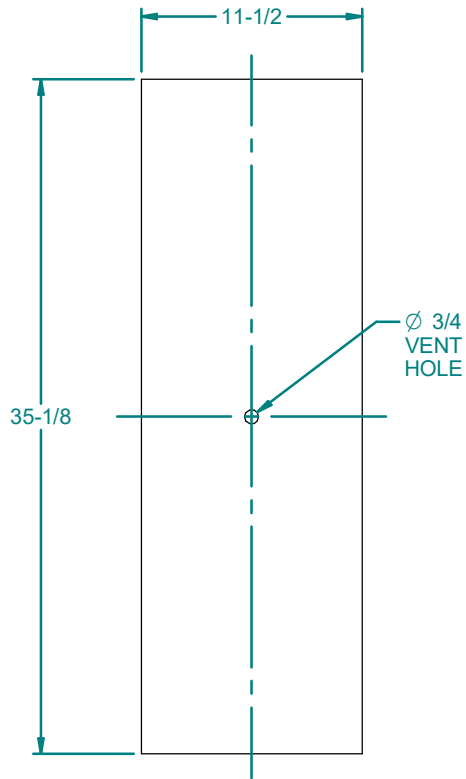

tanks are designed to be used in a horizontal position. rectangular tanks used in vertical position may require additional wall thickness or external support

tanks are not rated for gasoline or aromatic solvents

tank resins are fully uv stabilized

most size tanks are available in standard wall thickness shown or heavy duty

allow +/- 1% on tank dimensions for overall size variances

vent hole on tank will be welded shut if not used for fitting location

tank plastic resin is fda compliant based on manufacturer's specifications

tanks meet abyc and uscg requirements for marine water and holding tank applications

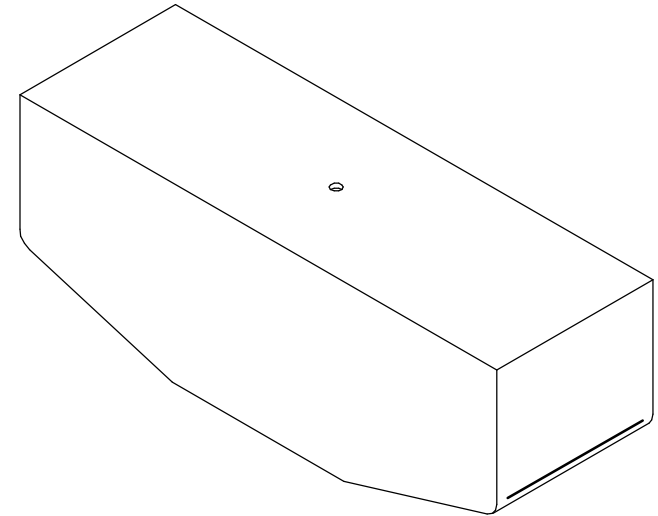
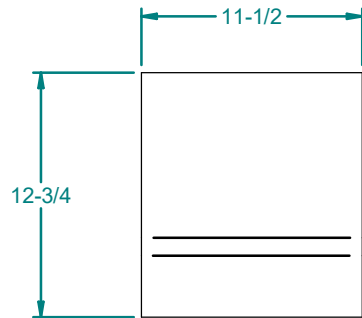

ISO View 208022

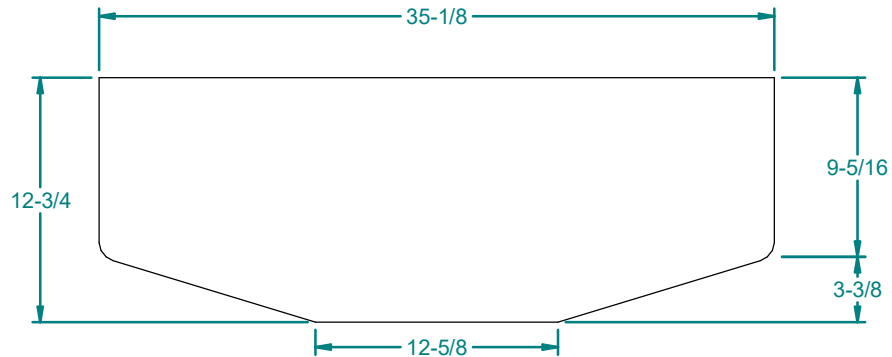

Weight: 16 lbm	NAME	DATE	 <p>16160 Hwy 27 Lake Wales, FL 33859</p>
Wall Thickness: 0.250 in	Drawn By: mnegron	6/22/2016	
Customer Part No: N/A	Customer APPR		Customer: Dura-Cast Products, Inc.
Print Date: 12/5/2019	Copyright©2019 Dura-Cast Products, Inc.		Part Title: 20 Gal Tank
UNLESS OTHERWISE SPECIFIED DIMENSIONS ARE IN INCHES AND TOLERANCES ARE:			File Name: 208022.dft
- DIMS > 10": ±1%	- PARTING LINE MISMATCH: ±3/32"	- STD WELDED RADII 3/16"	Size: A
- DIMS < 10": ±0.100	- PARTING LINE SEAL: 2 psi	- SWF ±3/8" (FREE HAND)	Material: LLDPE 939
- WALL THICKNESS: ±20%	- INSERT LOCATION: ±1%	- SWF ±1/8" + 1% (DRILL POINT)	Rev: 00
- FLATNESS: ±0.03 in/in	- GRAPHIC LOCATION: ±1%		Part No: 208022-MI100XXI
		Do Not Scale	Sheet: 1 OF 1