

tanks are designed to be used in a horizontal position. rectangular tanks used in vertical position may require additional wall thickness or external support

tanks are not rated for gasoline or aromatic solvents

tank resins are fully uv stabilized

most size tanks are available in standard wall thickness shown or heavy duty

allow +/- 1% on tank dimensions for overall size variances

vent hole on tank will be welded shut if not used for fitting location

tank plastic resin is fda compliant based on manufacturer's specifications

tanks meet abyc and uscg requirements for marine water and holding tank applications

| REVISION HISTORY | | | |
|------------------|-------------|------|----------|
| REV | DESCRIPTION | DATE | APPROVED |
| | | | |

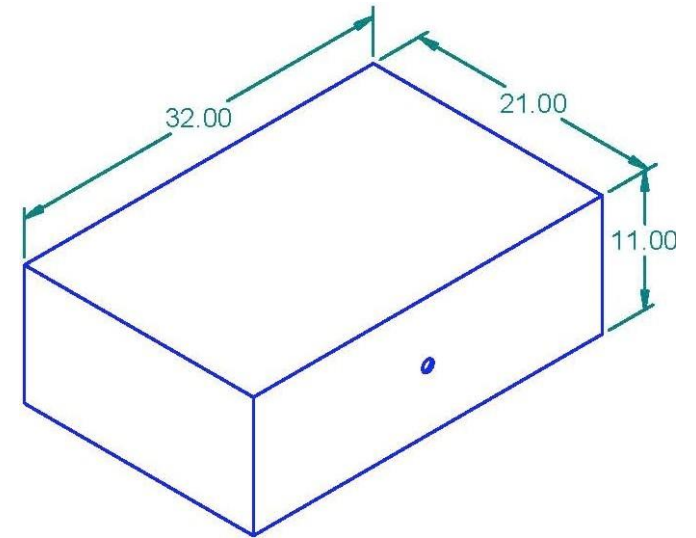

ISO View 130030

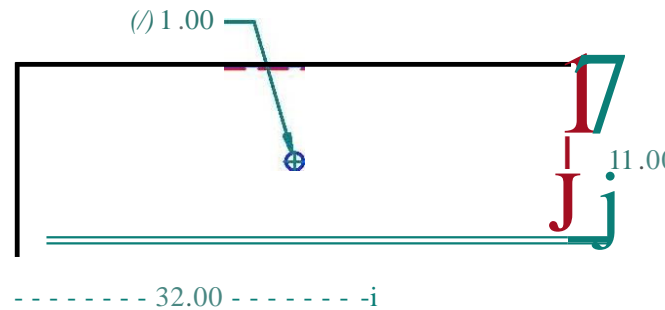
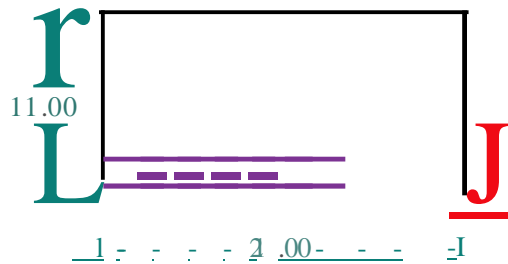

wall thickness: .200"

| Tank Capacity: 30 Gallons | | | | | | | | | | | | |
|--|----------|------|--|-------------|----------|---------|--|----------|--|----------|--|--|
| <table border="1"> <thead> <tr> <th>NAME</th> <th>DATE</th> </tr> </thead> <tbody> <tr> <td>DRAWN mputt</td> <td>5/8/2006</td> </tr> <tr> <td>CHECKED</td> <td></td> </tr> <tr> <td>ENG APPR</td> <td></td> </tr> <tr> <td>MGR APPR</td> <td></td> </tr> </tbody> </table> | NAME | DATE | | DRAWN mputt | 5/8/2006 | CHECKED | | ENG APPR | | MGR APPR | | 1610 Hwy 27 Lake Wales, FL 33859 TITLE 30Gallon Plastic Tank SIZE A MATERIAL LMDPE Natural REV |
| NAME | DATE | | | | | | | | | | | |
| DRAWN mputt | 5/8/2006 | | | | | | | | | | | |
| CHECKED | | | | | | | | | | | | |
| ENG APPR | | | | | | | | | | | | |
| MGR APPR | | | | | | | | | | | | |
| UNLESS OTHERWISE SPECIFIED DIMENSIONS ARE IN INCHES ANGLES ±05' 2 PL ±0.125 3PL ±0.060" | | | FILE NAME: 130030 .dft PART# 1 30030 WEIGHT 16.717 lbm SHEET 1 OF 1 | | | | | | | | | |