

TANKS ARE DESIGNED TO BE USED IN A HORIZONTAL POSITION. RECTANGULAR TANKS USED IN VERTICAL POSITION MAY REQUIRE ADDITIONAL WALL THICKNESS OR EXTERNAL SUPPORT

TANKS ARE NOT RATED FOR GASOLINE OR AROMATIC SOLVENTS

TANK RESINS ARE FULLY UV STABILIZED

MOST SIZE TANKS ARE AVAILABLE IN STANDARD WALL THICKNESS SHOWN OR HEAVY DUTY

ALLOW +/- 1% ON TANK DIMENSIONS FOR OVERALL SIZE VARIANCES

VENT HOLE ON TANK WILL BE WELDED SHUT IF NOT USED FOR FITTING LOCATION

TANK PLASTIC RESIN IS FDA COMPLIANT BASED ON MANUFACTURER'S SPECIFICATIONS

TANKS MEET ABYC AND USCG REQUIREMENTS FOR MARINE WATER AND HOLDING TANK APPLICATIONS

| REVISION HISTORY | | | |
|------------------|-------------|------|----------|
| REV | DESCRIPTION | DATE | APPROVED |
| | | | |

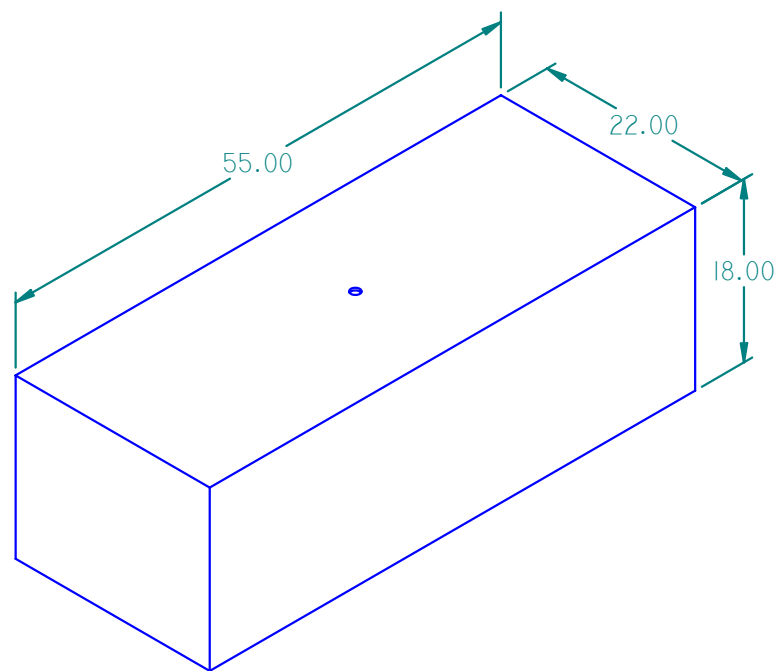

ISO VIEW 207095

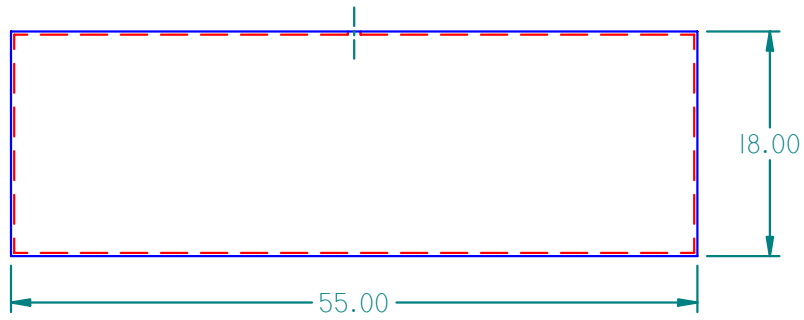
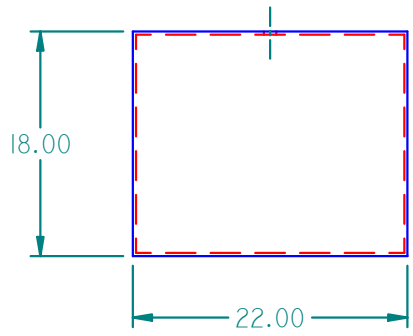

| | | |
|---|-------|-----------|
| TANK CAPACITY: 90 GALLONS | | |
| | NAME | DATE |
| DRAWN | MPUTT | 1/26/2004 |
| CHECKED | | |
| ENG APPR | | |
| MGR APPR | | |
| UNLESS OTHERWISE SPECIFIED DIMENSIONS ARE IN INCHES ANGLES ±0.5° 2 PL ±0.125" 3 PL ±0.060" | | |

WALL THICKNESS: .255"

Dura-Cast Products INC.
Automolding Plastic for the Future

16160 Hwy 27 Lake Wales, FL 33859

TITLE 90 GALLON PLASTIC TANK

| | | |
|--------|-------------------------|-----|
| SIZE A | MATERIAL: LMDPE NATURAL | REV |
|--------|-------------------------|-----|

FILE NAME: 207095.DFT

| | | |
|---------------|--------------------|--------------|
| PART#: 207095 | WEIGHT: 44.172 LBM | SHEET 1 OF 1 |
|---------------|--------------------|--------------|